

# Plan-Enhanced Ubiquitous Computing

Gary Look, Stephen Peters, Howard Shrobe  
MIT Computer Science and AI Lab (CSAIL)

November 11, 2003  
AIMS 2003

*AIRE*

## Talk Outline

- An introduction to AIRE
- Plan-enhanced ubiquitous computing
- Plan selector
- Resource manager
- Future work
- Recap

*AIRE*

# The AIRE Project

- Agent-Based Intelligent Reactive Environments
- Software deployed in a wide variety of spaces (intelligent environments, or IEs)

*aire*

# The AIRE Project



Kiosks



Conference Rooms

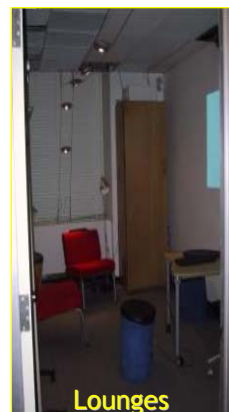

Lounges



Software Labs

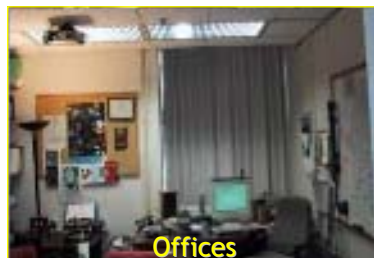

Offices



Handheld Devices

*aire*

# Applications

- Gaze-aware Interface (“Look-to-talk”)
- Sketch-based configuration tool
- Meeting Management
- NewsWall



# AIRE in Action

## Talk Outline

- An introduction to AIRE
- Plan-enhanced ubiquitous computing
- Plan selector
- Resource manager
- Future work
- Recap

*aire*

## Beyond Plumbing

- Ubicomp is becoming more human-centered
- For IEs, the driving question
  - isn't "what plumbing do we need to enable device control?"
  - is "what does the IE need to know so that it can react in a reasonable manner?"
- Our approach: give the IE a representation of the plan a person is trying to carry out
- Use a knowledge representation (semantic network) to make inferences

*aire*

## Overall Model

- Context (in particular, task context)
- Preferences
- Plans

*aire*

## System Architecture

- Plan selector
- Resource manager
- Plan executor
- Plan monitor

*aire*

## Talk Outline

*aire*

- An introduction to AIRE
- Plan-enhanced ubiquitous computing
- Plan selector
- Resource manager
- Future work
- Recap

## Plan Selection

*aire*

- Multiple plans can accomplish the same goal
- Each plan requires different resources
- Each “resourced plan” offers different qualities of service
- Users have preferences over different qualities of service
- Preferences change based on context

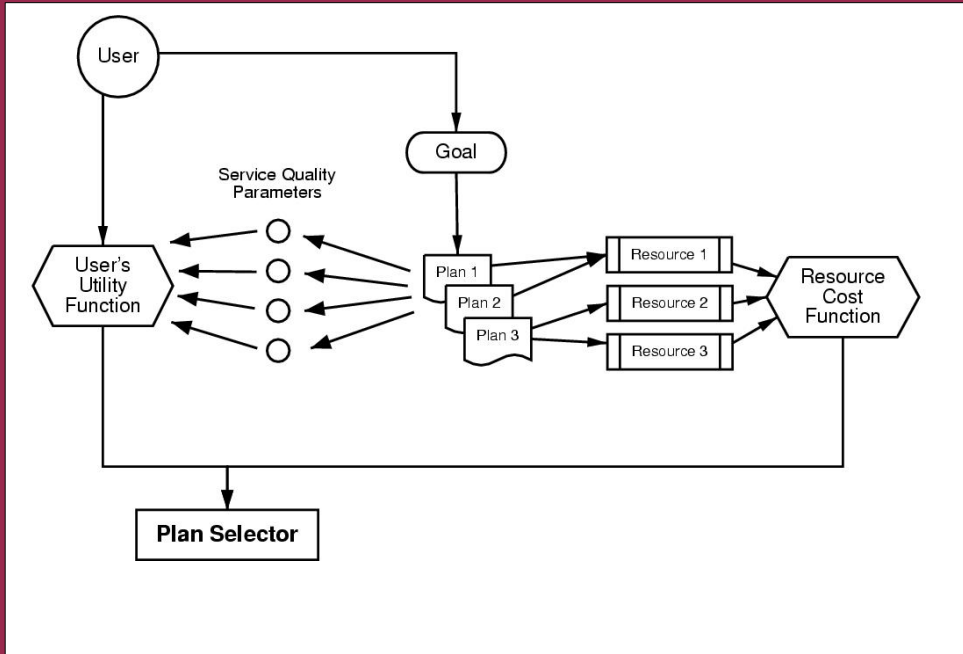

## Plan Selection Process

- Assign a cost to each resource
- Transform the user's preferences to a utility function (McGeachie and Doyle '02)
- Create a library of plans that achieve different goals
- When presented a goal, find the best plan and resource combination to maximize utility to cost ratio

## Example: Illuminating a Room

- Different ways of illuminating a room (e.g., opening the drapes, turning on a lamp)
- Each way requires different resources (e.g., a drapes controller, a lamp)
- Assume resource cost as follows:
  - drapes controller costs 2 units
  - overhead fluorescent lights cost 1 unit
  - halogen lamp costs 1 unit

are

## Example (cont)

- Quality of service can be measured on a number of axes (e.g., source, intensity, privacy)
- Each resource provides a different quality of service
  - drapes controller offers no privacy
  - fluorescent lights offer high intensity
  - halogen lamp offers medium intensity
- `\((source natural (>> 2) source artificial)  
(intensity med (>> 3) intensity high)  
(source natural (>> 5) privacy private))`

are

## Example (cont)

- Utility of opening the drapes with the drapes controller: 64
  - Utility of turning on the fluorescent lights: 8
  - Utility of turning on the halogen lamp: 24
  - Utility to cost ratio:
    - Opening drapes:  $64/2 = 32$
    - Turning on fluorescent lights =  $8/1 = 8$
    - Turning on halogen lamp =  $24/1 = 24$
- Open the drapes using the drapes controller

*AIRE*

## Talk Outline

- An introduction to AIRE
- Plan-enhanced ubiquitous computing
- Plan selector
- Resource manager
- Future work
- Recap

*AIRE*

## Resource Manager

- Provides resource cost information to plan selector
- Resource arbitration and allocation
- Uses a semantic network to rank appropriateness of resources according to context

*aire*

## Future Work

- Sources of context and preferences
- Plan recognition/plan monitoring
- Diagnosis and recovery

*aire*

## Recap

- Plans as a way of directing IE behavior
- Context drives preferences which drives plan selection
- A system that takes a first cut at this paradigm

*aire*

## About Us

**The AIRE Project**  
(formerly the Intelligent Room)

MIT Computer Science and AI Lab  
<http://www.ai.mit.edu/projects/aire>

[garyl@ai.mit.edu](mailto:garyl@ai.mit.edu)  
[aire-contact@ai.mit.edu](mailto:aire-contact@ai.mit.edu)

*aire*